

Bellini
MODERN LIVING

GENOA extendable



Made in Italy

**Avvertencia****Utilizar para su finalidad prevista:**

Asegúrese de que sus muebles se usen solo para el propósito para el que fueron hechos. Para garantizar su funcionamiento a lo largo del tiempo, es importante utilizarlos correctamente y someterlos regularmente a mantenimiento.

Mises en garde**Utilisation conforme:**

Veillez vous assurer que vos meubles sont utilisés uniquement pour leur usage prévu. Un entretien régulier et une utilisation conforme sont essentiels pour assurer un fonctionnement durable.

Avvertenze**Utilizzo per lo scopo previsto:**

assicuratevi che i vostri mobili siano utilizzati solo per lo scopo per cui sono stati realizzati. Per garantire il loro funzionamento nel tempo è importante utilizzarli correttamente e sottoporli regolarmente a cure manutentive.

Warning notice**Intended use:**

Please make sure that you only use your furniture for the purpose it was designed for. Correct use and regular maintenance are essential for ensuring your furniture remains in working order for the long-term.

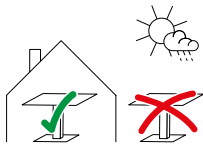
**Usar:**

El mueble que ha comprado es apto únicamente para uso privado. No es apto para exterior.

Usage:

Le meuble que vous avez acheté ne convient qu'à un usage privé. Ne convient pas pour l'extérieur.

Impiego:

Il mobile che ha acquistato è adatto solo per uso privato. Non è adatto per esterno.

Area of use:

The piece of furniture you have purchased is suitable only for private use. Is not suitable for outdoor.

**Usar:**

no está permitido sentarse o pararse sobre la mesa, no reemplaza un escalón o escalera.

Usage:

Il n'est pas permis de s'asseoir ou de se mettre debout sur la table, elle n'est pas un substitut aux escabeaux ou échelles.

Impiego:

non è consentito sedersi o stare in piedi sul tavolo, non sostituisce un gradino o una scala.

Area of use:

Sitting and standing on the furniture is not permitted, the table is not a substitute for steps or ladders.

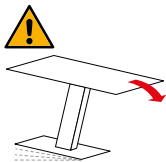
**PRECAUCIÓN, este mueble puede volcarse:**

asegúrese de colocar la mesa de manera estable.

PRÉCAUTION, cette meuble peut basculer:

S'assurer que la table soit stable.

PRECAUZIONE, questo mobile può ribaltarsi:

assicurarsi di posizionare il tavolo in modo stabile.

PRECAUTION, this furniture can tip over:

Make sure the table is positioned on a stable surface.

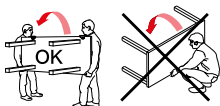

No pivote sobre las patas de la mesa para volcarla.

Ne posez pas les pieds de la table sur le sol, pour la faire tourner.

Non fare perno sulle gambe del tavolo per capovolgerlo.

Do not pivot on the table legs to turn it over.

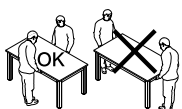

Para pequeños movimientos: levante el mueble suavemente, agarrándolo lo más cerca posible del punto de fijación de la base/patas. Para grandes movimientos: desmontar el mueble siguiendo los pasos de montaje en orden inverso.

Pour les petits déplacements: soulevez doucement le meuble, en le saisissant aussi près que possible du point de fixation de la base / des pieds. Pour les grands déplacements: démontez le meuble en suivant les étapes de montage en sens inverse.

Per piccoli spostamenti: sollevare il mobile delicatamente, afferrandolo il più vicino possibile al punto di fissaggio del basamento / gambe. Per grandi spostamenti: disassemblare il mobile percorrendo all'inverso le fasi di assemblaggio.

For small movements: lift the piece of furniture gently, grasping it as close as possible to the fixing point of the base / legs. For big movements: disassemble the piece of furniture by following the assembly steps in reverse.



Carga máxima:
150 kg

Charge max.:
150 kg

Carico max.:
150 kg

Max. load:
150 kg

**Advertencias****Mises en garde****Avvertenze****Warning notice**

ADVERTENCIA
Peligro de ingestión y asfixia:
Kleinteile und las piezas pequeñas y el material de embalaje pueden tragarse.

AVERTISSEMENT
Risque d'ingestion et d'étouffement:
Les petites pièces et le matériel d'emballage peuvent être avalés.

AVVERTENZA
Pericolo di ingestione e soffocamento:
piccole parti e materiale di imballaggio possono essere ingerite.

WARNING
Risk of swallowing and choking:
Small parts and packaging material may be swallowed.



ADVERTENCIA! Las bolsas y las películas no son un juguete! Manténgase fuera del alcance de los bebés y niños pequeños! ¡No te los pongas en la cabeza, peligro de asfixia!Erstickungsgefahr!

AVERTISSEMENT!
Les sacs et films ne sont pas des jouets! Veuillez les tenir hors de portée des bébés et jeunes enfants! Ne pas mettre sur la tête, risque d'étouffement!

AVVERTENZA! Sacchetti e pellicole non sono un giocattolo! Tenere lontano dalla portata dei neonati e dei bambini piccoli! Non metterli in testa, pericolo di soffocamento!

WARNING! Bags and film coverings are not toys! Please keep away from babies and small children! Do not put them over your head, risk of suffocation!



PRECAUCIÓN,
peligro de lesiones:
Mantenga a los niños alejados del lugar de montaje y evite que se cuelguen o se suban a los muebles.

PRÉCAUTION,
risque de blessures:
Les jeunes enfants ne peuvent pas se tenir dans la zone de montage ni tirer ou grimper sur des meubles.

PRECAUZIONE,
pericolo di lesioni:
tenere i bambini lontano dal luogo di montaggio e evitare che si appendano o arrampichino sul mobile.

PRECAUTION,
risk of injury:
Small children must keep away from the assembly area. They must refrain from climbing up on the furniture.

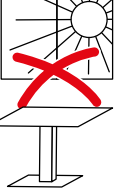
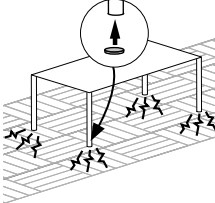
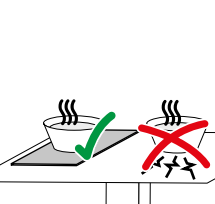
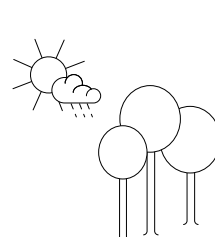
1.	Advertencias general	Remarques générales	Avvertenze generali	General information
	ATENCIÓN Luz solar directa: cambia su color.	ATTENTION Exposition directe au soleil: Provoque des décolorations.	ATTENZIONE Irraggiamento diretto del sole: ne modifica il colore.	ATTENTION Direct sunlight: results in discolouration.
	Deslizamiento protector: gracias a los protectores deslizantes (p. ej. fieltro) evita dañar los suelos sensibles a los arañazos (p. ej. parquet).	Patins: Les patins (p.ex. en feutre) permettent d'éviter d'endommager les sols sensibles aux rayures (p.ex. parquet).	Scivolante protettivo: grazie agli scivolanti protettivi (ad es. feltro) si evita di danneggiare pavimenti sensibili ai graffi (ad es. parquet).	Protective covers: Protective covers, e.g. felt pads, prevent damage to floors that are easily scratched (e.g. parquet).
	ATENCIÓN, temperatura: nunca coloque objetos calientes o muy fríos directamente sobre la superficie. Utilice una protección adecuada, p. una placa secundaria. No coloque los muebles demasiado cerca de fuentes de calor.	ATTENTION, température: Ne jamais poser des objets chauds ou très froids directement sur la surface. Utiliser une protection appropriée, p.ex. sous-plat. Ne pas placer le meuble trop près des sources de chaleur.	ATTENZIONE, temperatura: non appoggiare mai oggetti caldi o molto freddi direttamente sulla superficie. Utilizzare una protezione adatta, ad es. un sotto piatto. Non posizionare il mobile troppo vicino a fonti di calore.	ATTENTION, temperature: Do not place hot or cold objects directly on the surface. Use the appropriate protection, e.g. saucer. Do not place furniture too close to a heat source.
	Productos de madera: la madera es una materia prima natural. Cada árbol, dependiendo de dónde crece, está expuesto a diferentes influencias como el clima, etc. Gracias a estos agentes se influye fuertemente en el aspecto (color, ramas, vetas, etc.) de la madera. Dependiendo de la humedad del aire y la temperatura, la madera tiene la capacidad de expandirse y contraerse. Esto puede conducir a la formación de grietas. La transformación y las características son naturales y, por tanto, cada mueble de madera maciza es único.	Produits en bois: Le bois est une matière naturelle. Chaque arbre est exposé à diverses influences, comme le climat etc., en fonction de son lieu de plantation. L'aspect du bois (teinte, nœuds, grain etc.) est fortement conditionné par ces influences. Le bois a la propriété de se dilater ou de se rétracter en fonction de l'humidité et de la température. Cela peut provoquer des fissures. Ces caractéristiques naturelles et les changements sont normaux, ce qui fait de chaque meuble en bois une pièce unique.	Prodotti di legno: il legno è una materia prima naturale. Ogni albero, a seconda del luogo in cui cresce, è esposto a diverse influenze come il clima, ecc. Grazie a questi agenti, l'aspetto (colore, rami, venatura, ecc.) del legno viene fortemente influenzato. A seconda dell'umidità dell'aria e della temperatura, il legno ha la capacità di espandersi e ritirarsi. Questo può portare alla formazione di crepe. La trasformazione e le caratteristiche sono naturali e, pertanto, ogni mobile di legno massiccio è unico nel suo genere.	Wooden products: Wood is a natural raw material. Each tree is subjected to a whole variety of influences, e.g. the climate, depending on its location. These influences are decisive in creating the way the wood ultimately looks (colour, knots, grain, etc.) Depending on the humidity and temperature, wood is capable of expanding and contracting. As a result cracks may form. Changes and natural characteristics are natural, so each piece of solid wood furniture completely unique.
	Ejemplar único: este producto ha sido hecho a mano y cada pieza es una pieza única.	Pièce unique: Ce produit a été réalisé à la main et chaque pièce est unique.	Esemplare unico: questo prodotto è stato realizzato a mano e ogni esemplare è un pezzo unico.	Unique: This product has been made by hand and therefore each piece is unique.

2.

Instrucciones de montaje

Instructions de montage

Istruzioni di montaggio

Assembly information

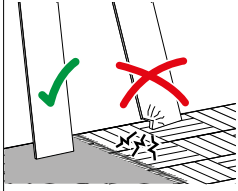

Daños en curso montaje:

Evite causar daños utilizando una base limpia y suave (por ejemplo, una alfombra). Durante el desembalaje y el montaje, coloque las piezas únicamente sobre una base blanda. Tenga cuidado de que las piezas más grandes no se vuelquen.

Dommages au montage:

Évitez les dommages en utilisant un fond propre et doux (p.ex. tapis). Lors du déballage et montage, posez/placez les éléments uniquement sur un fond doux. Assurez-vous que les grands éléments ne peuvent pas basculer.

Danni in fase di montaggio:

evitare di causare danni utilizzando una base pulita e morbida (ad es. tappeto). Nella fase di disimballaggio e durante il montaggio, appoggiare i pezzi esclusivamente su una base morbida. Fare attenzione che i pezzi più grandi non si ribaltino.

Damages during assembly:

These can be avoided if you use a clean soft surface (e.g. carpet). Only place parts on a soft surface when unpacking or during the assembly. Make sure that larger parts cannot tip over.



Personas: Número de personas necesarias para el montaje.

Personnes: Nombre de personnes nécessaires au montage.

Persone: numero di persone necessarie per il montaggio.

People: Number of people required for the assembly.



Tiempo de ensamblaje: tiempo aproximado 50 min.

Durée indicative du montage: Durée approximative en 50 min.

Tempo di montaggio: tempo approssimativo 50 min.

Assembly time: Approximate time in 50 min.

Herramientas necesarias

Outils nécessaires

Attrezzi necessari

Tools required

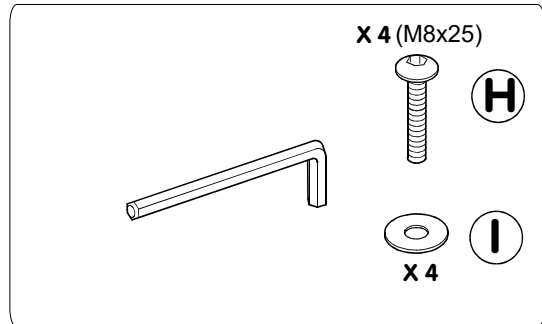
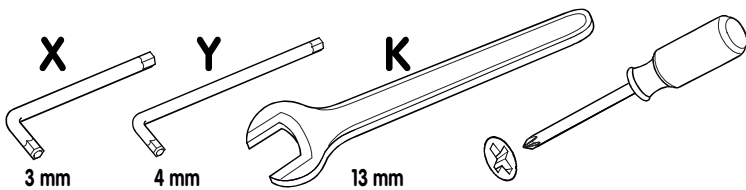

Componentes / Pequeñas piezas:

Éléments / pièces:

Componenti / piccoli pezzi

Components / small parts

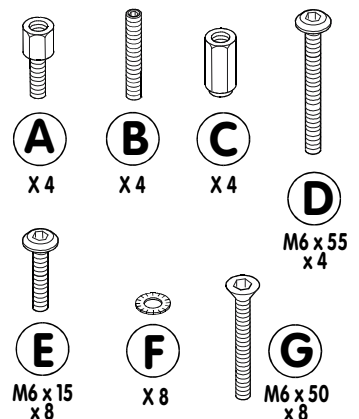
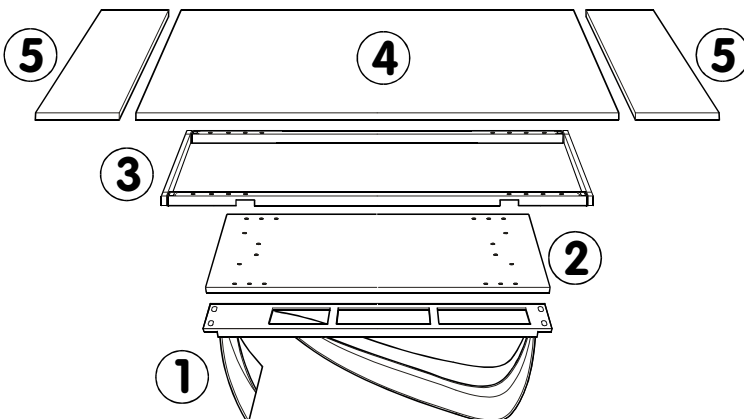

3.

Instrucciones
para el montaje

Instructions de
montage

Istruzioni per
il montaggio

Assembling
instruction

1

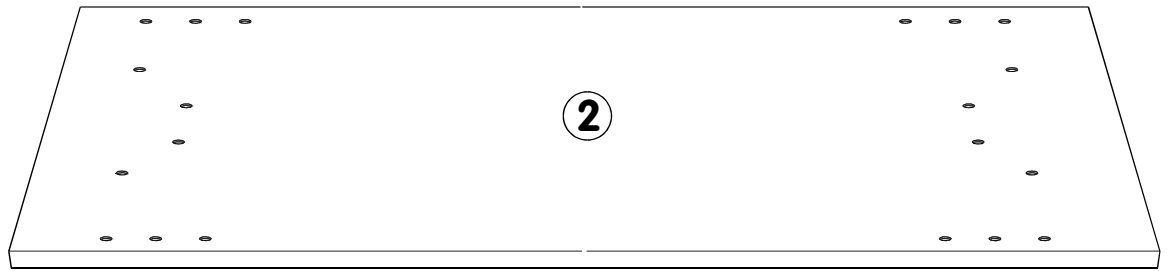

1

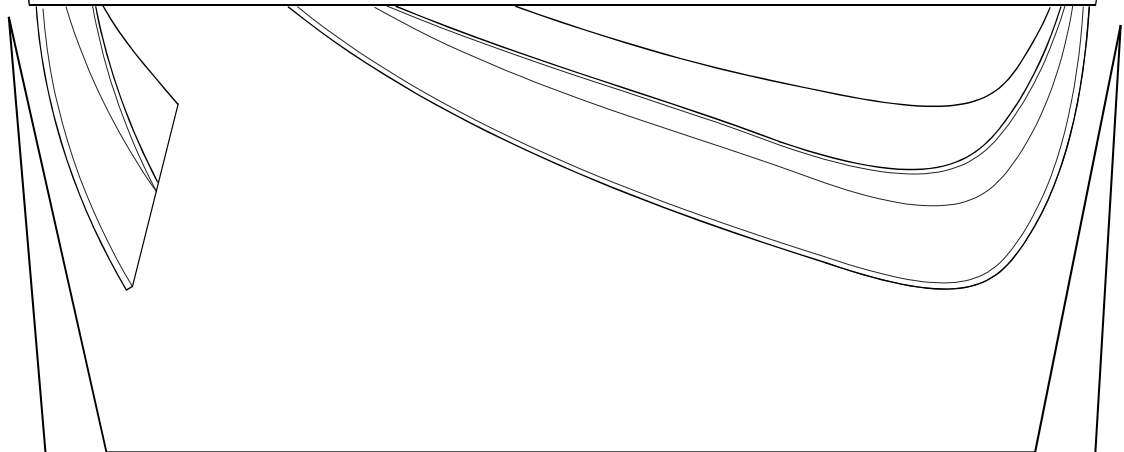
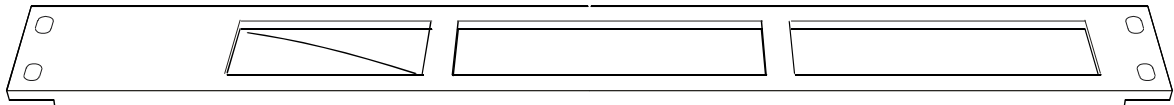

2

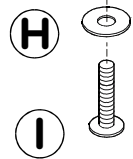
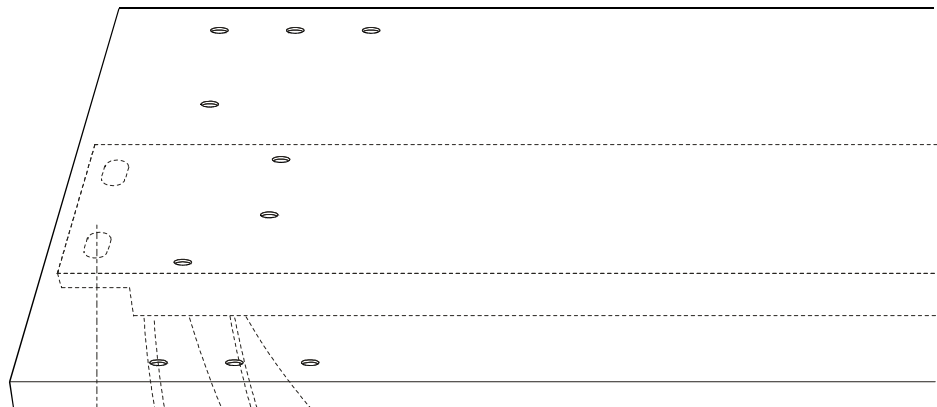

3.

Instrucciones
para el montaje

Instructions de
montage

Istruzioni per
il montaggio

Assembling
instruction

3

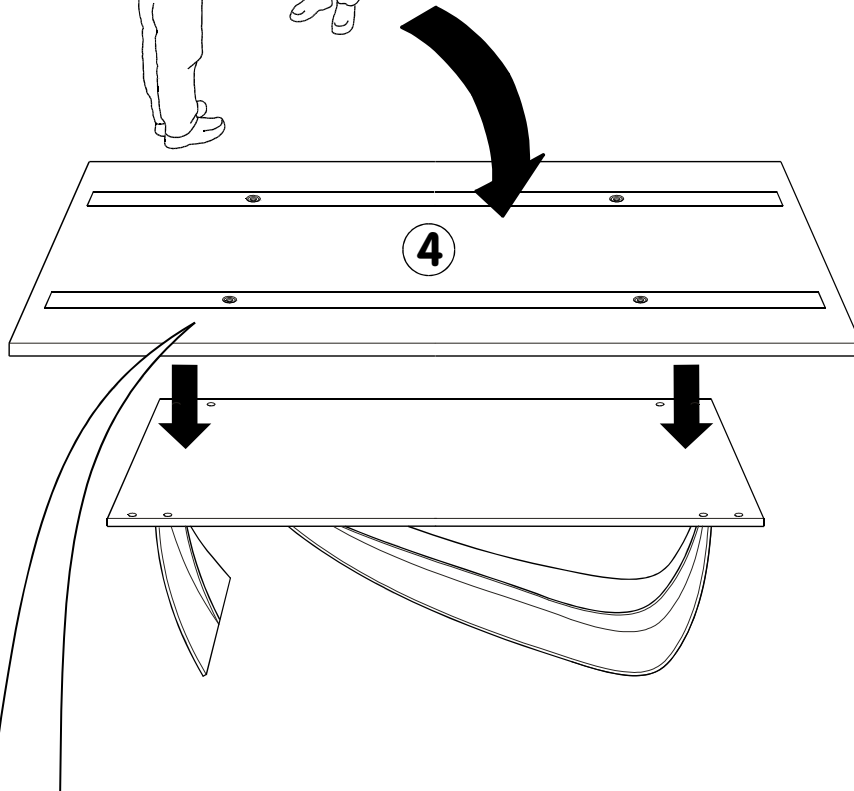
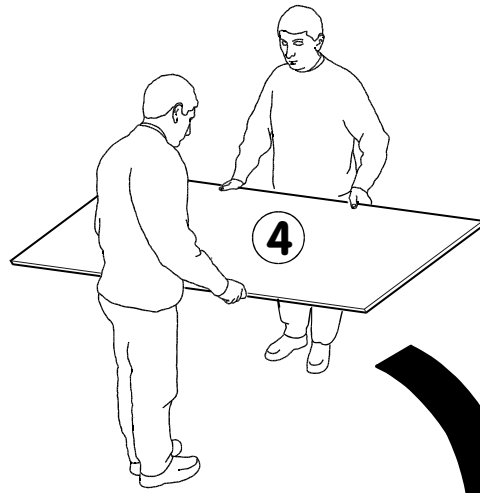

4

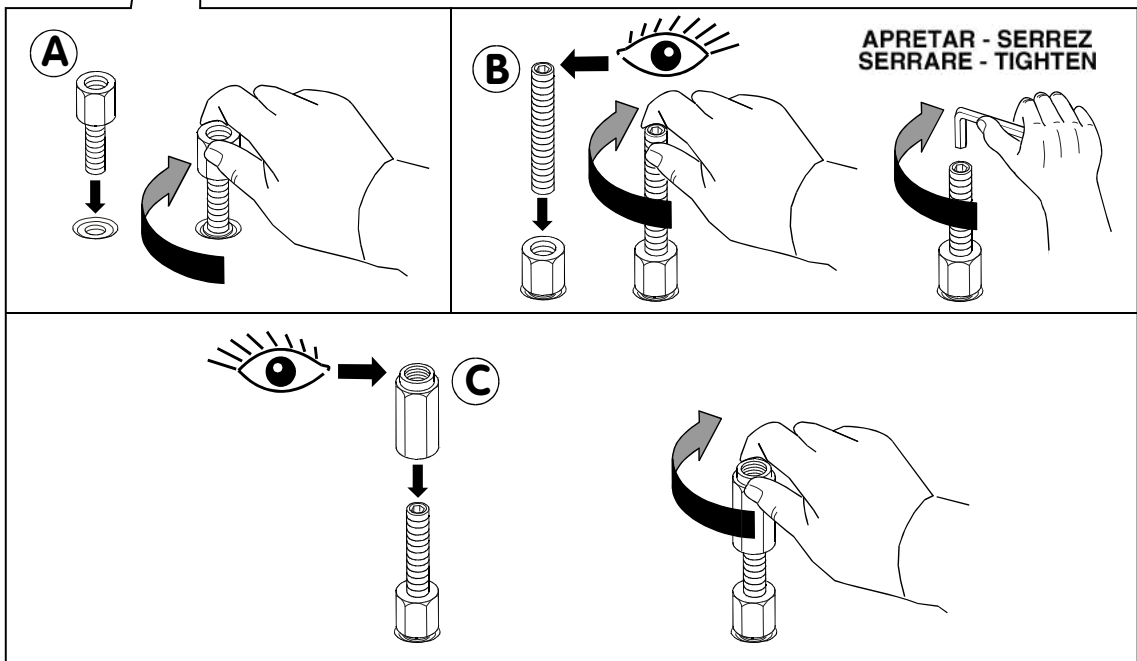

3.

Instrucciones
para el montaje

Instructions de
montage

Istruzioni per
il montaggio

Assembling
instruction

5

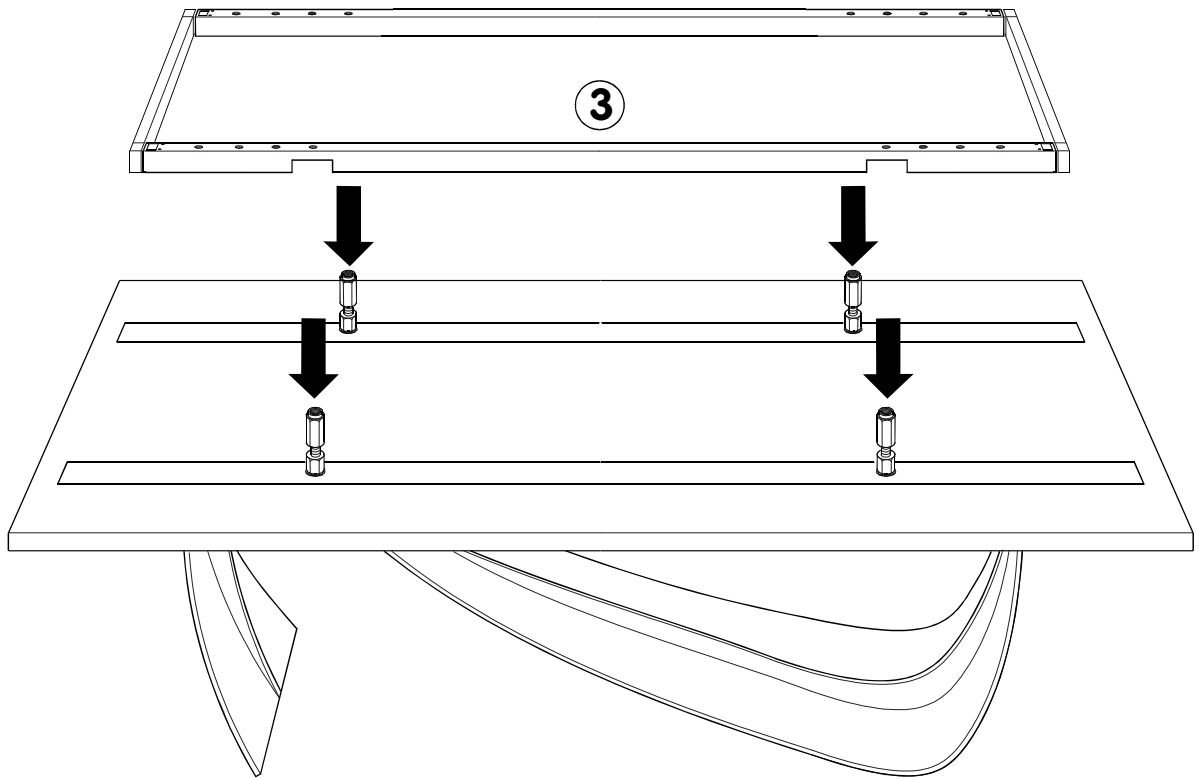

6

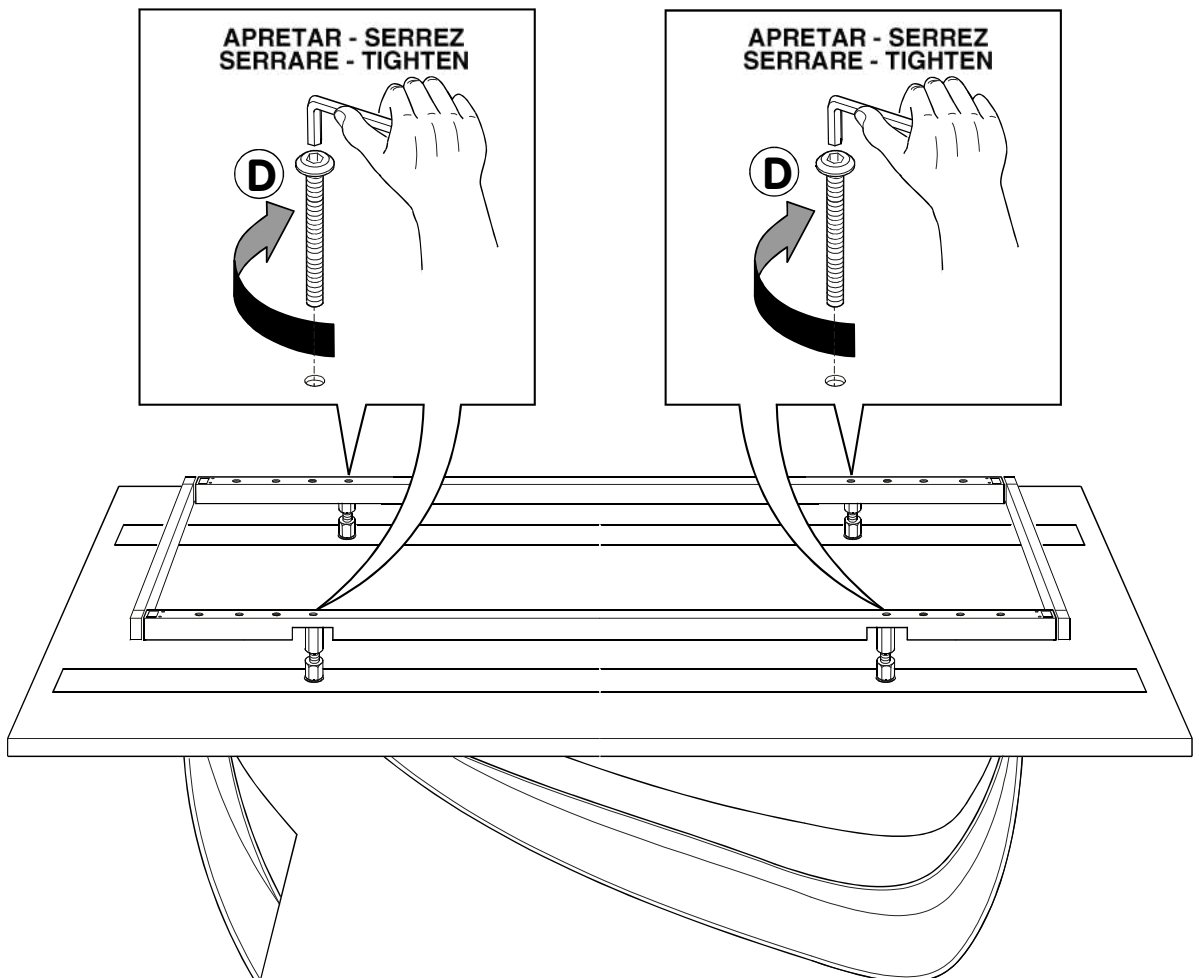

3.

Instrucciones
para el montaje

Instructions de
montage

Istruzioni per
il montaggio

Assembling
instruction

7

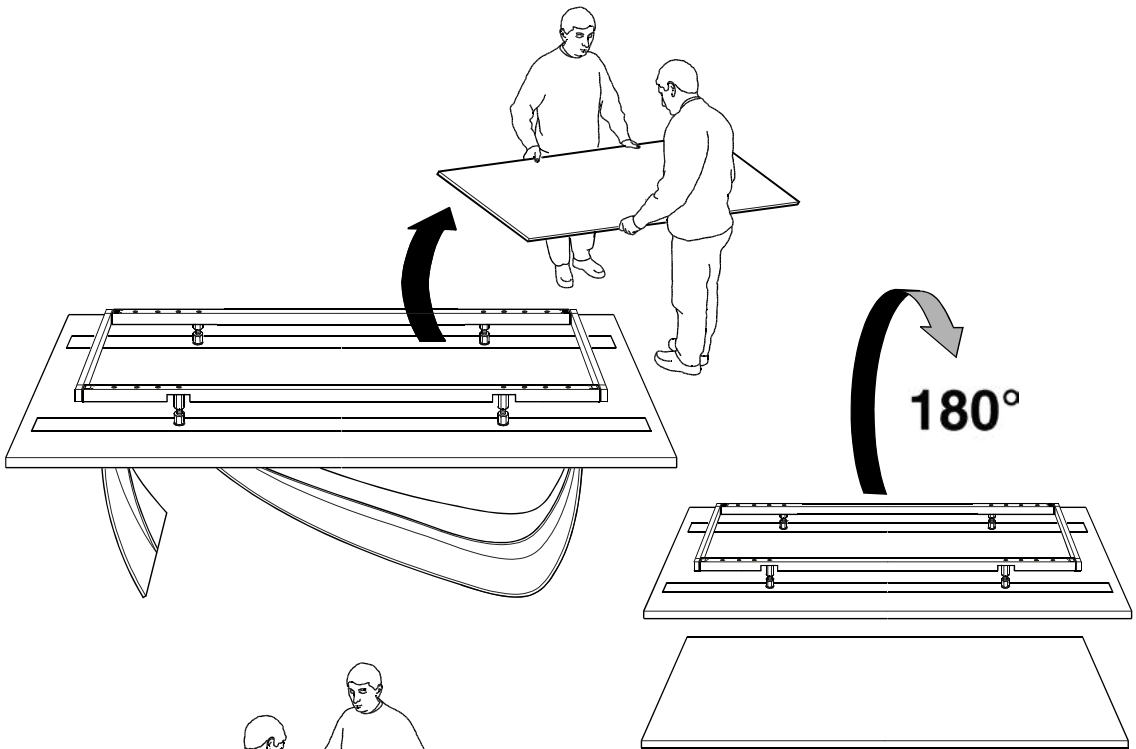

8

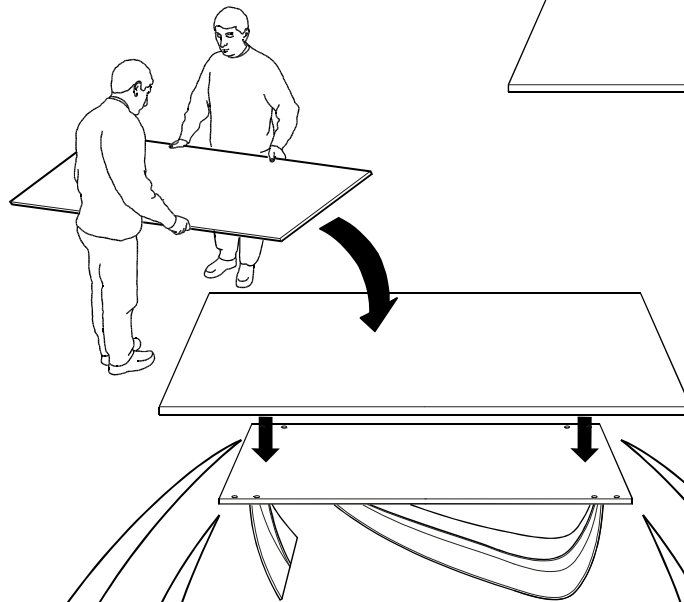

9

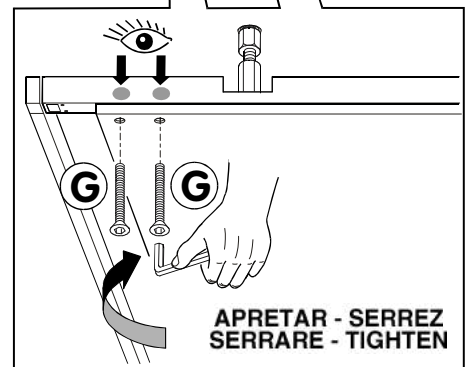
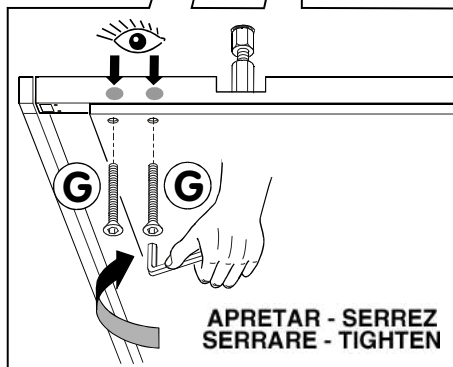

3.

Instrucciones
para el montaje

Instructions de
montage

Istruzioni per
il montaggio

Assembling
instruction

10

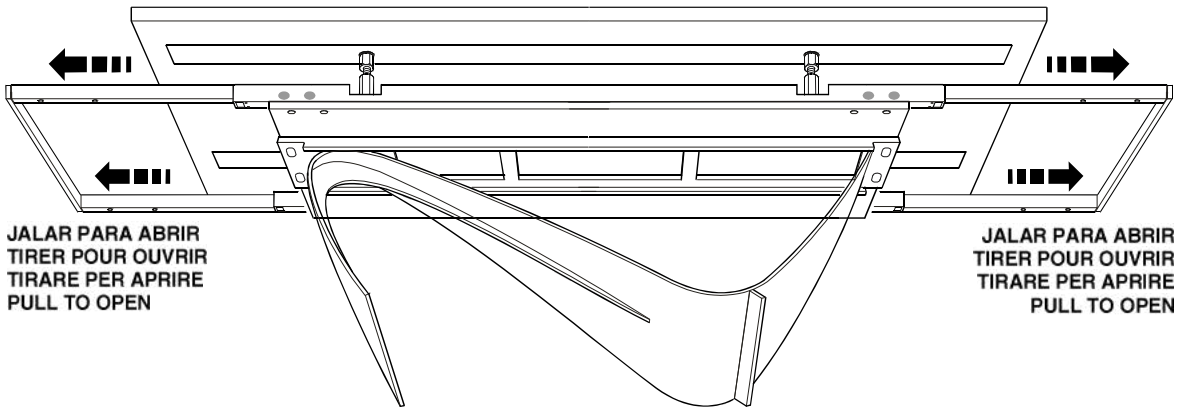

JALAR PARA ABRIR
TIRER POUR OUVRIR
TIRARE PER APRIRE
PULL TO OPEN

JALAR PARA ABRIR
TIRER POUR OUVRIR
TIRARE PER APRIRE
PULL TO OPEN

11

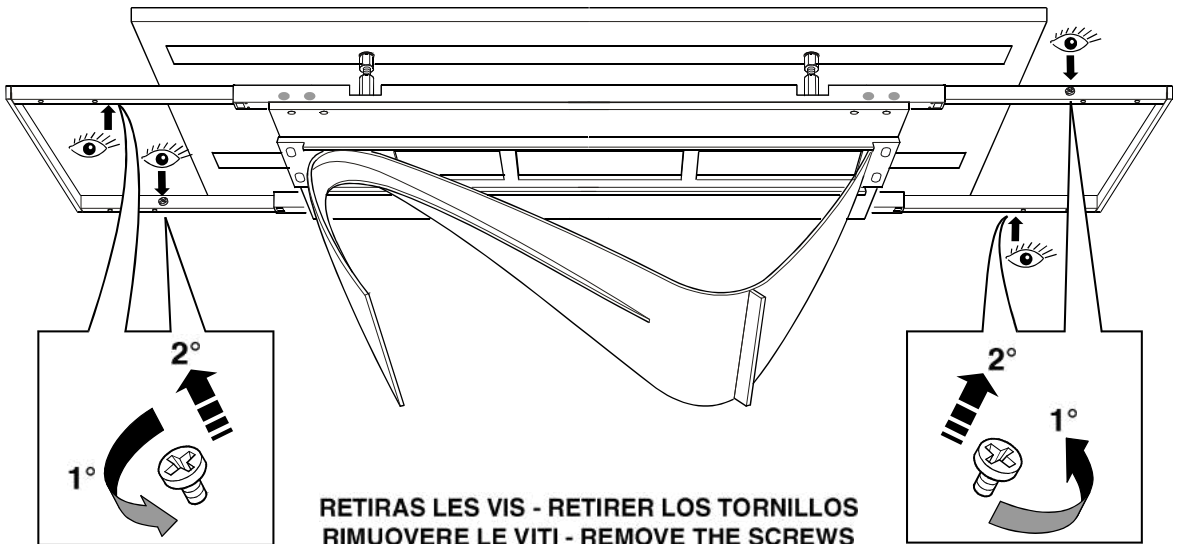

RETIRAS LES VIS - RETIRER LOS TORNILLOS
RIMUOVERE LE VITI - REMOVE THE SCREWS

12



TIRE FIRMEMENT PARA LEVANTAR
TIREZ FERMEMENT POUR SOULEVER
TIRARE CON DECISIONE PER SOLLEVARRE
PULL FIRMLY TO LIFT UP

TIRE FIRMEMENT PARA LEVANTAR
TIREZ FERMEMENT POUR SOULEVER
TIRARE CON DECISIONE PER SOLLEVARRE
PULL FIRMLY TO LIFT UP

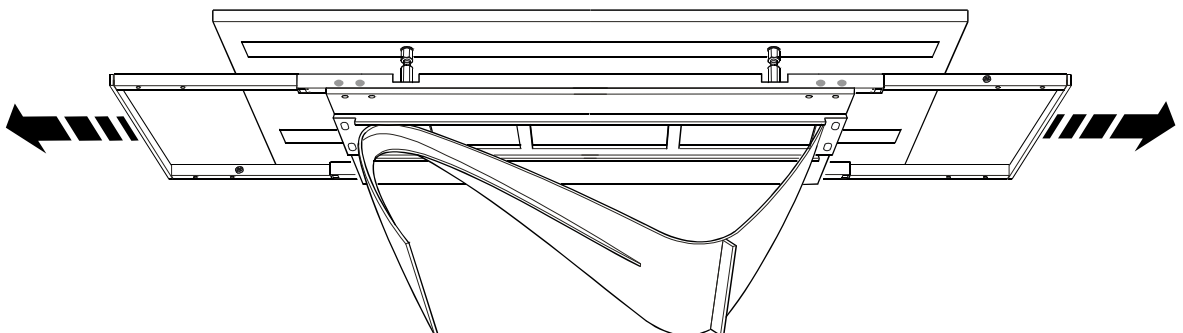

3.

Instrucciones
para el montaje

Instructions de
montage

Istruzioni per
il montaggio

Assembling
instruction

13

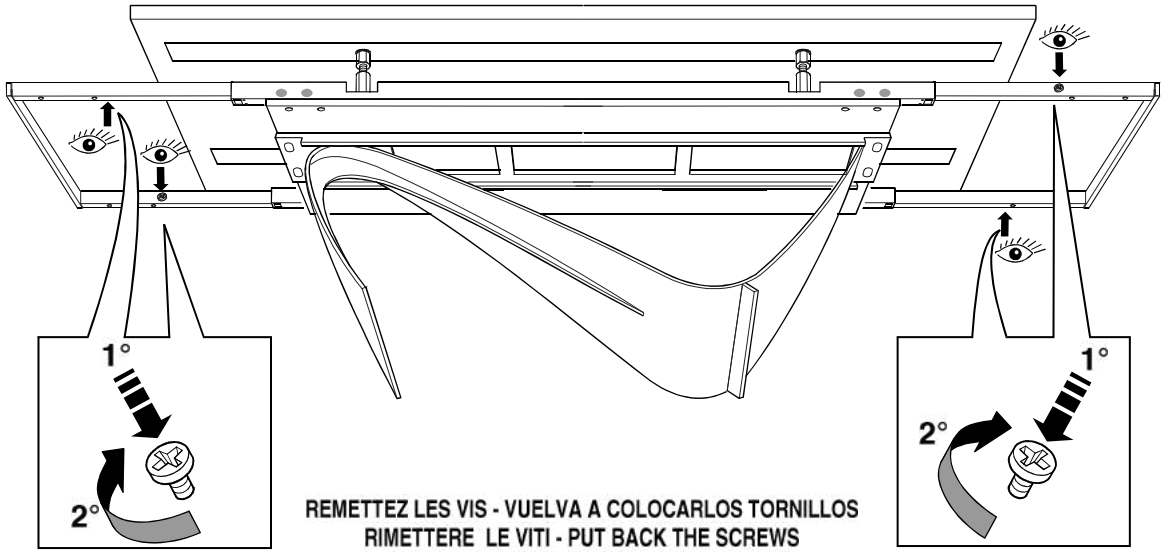

14

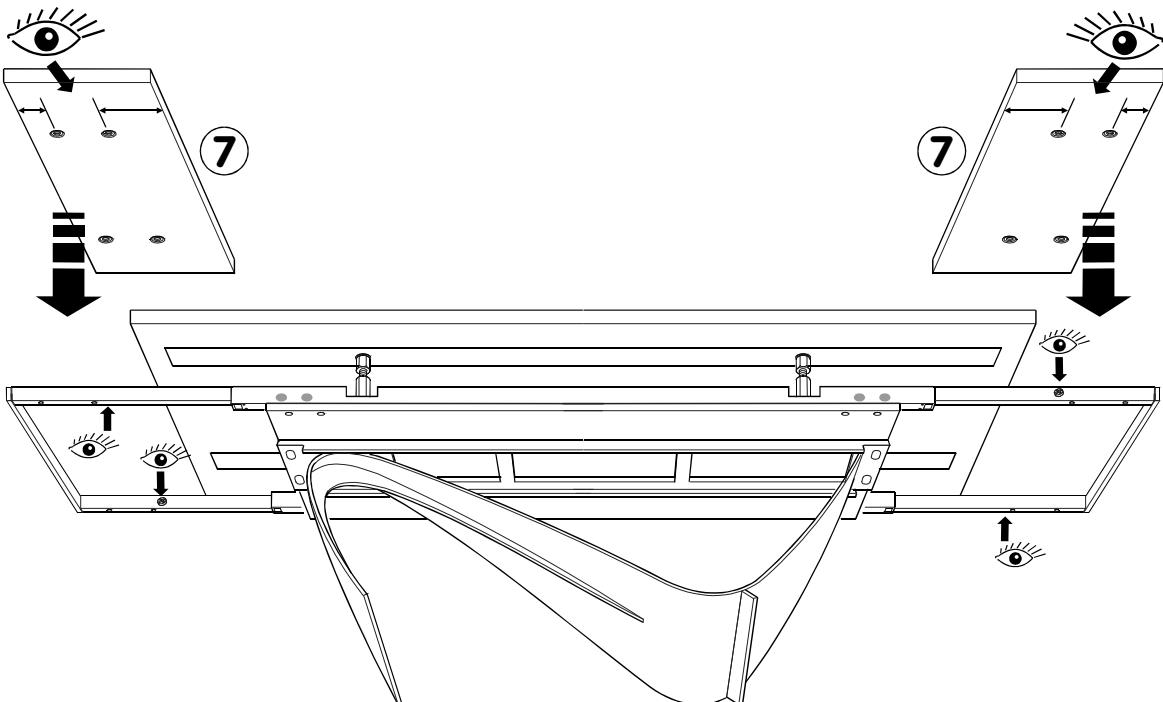

3.

Instrucciones
para el montaje

Instructions de
montage

Istruzioni per
il montaggio

Assembling
instruction

15

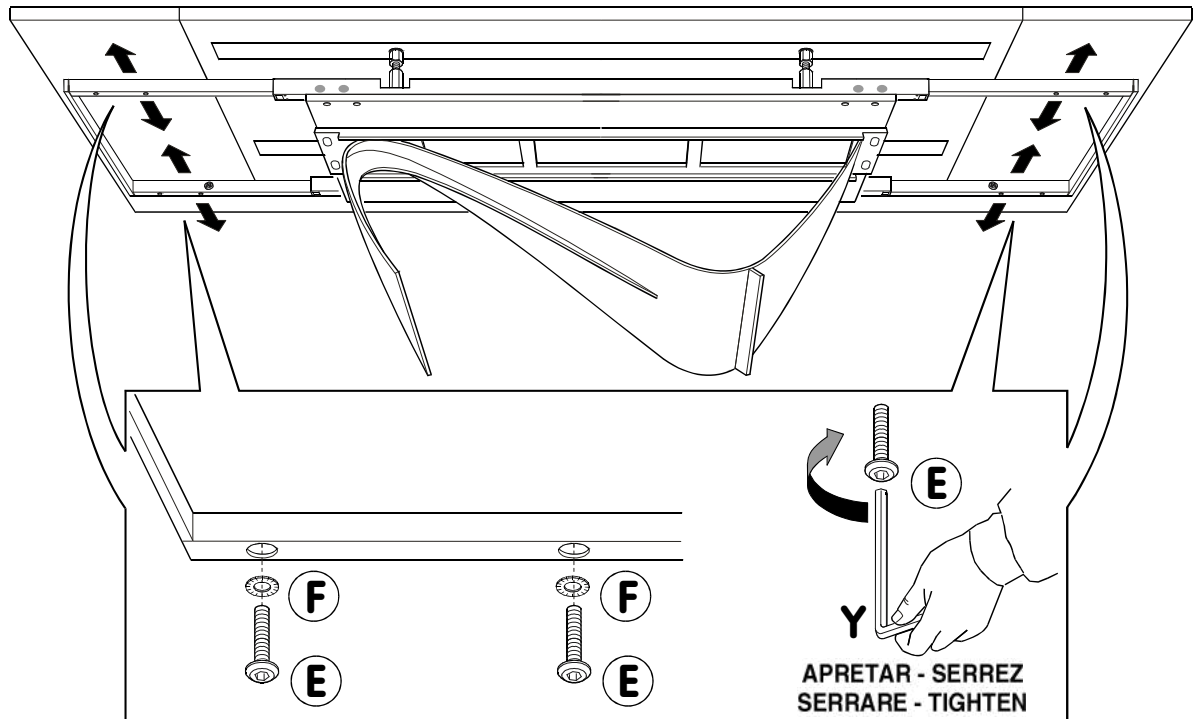

16

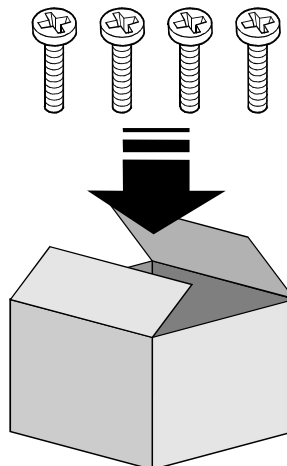
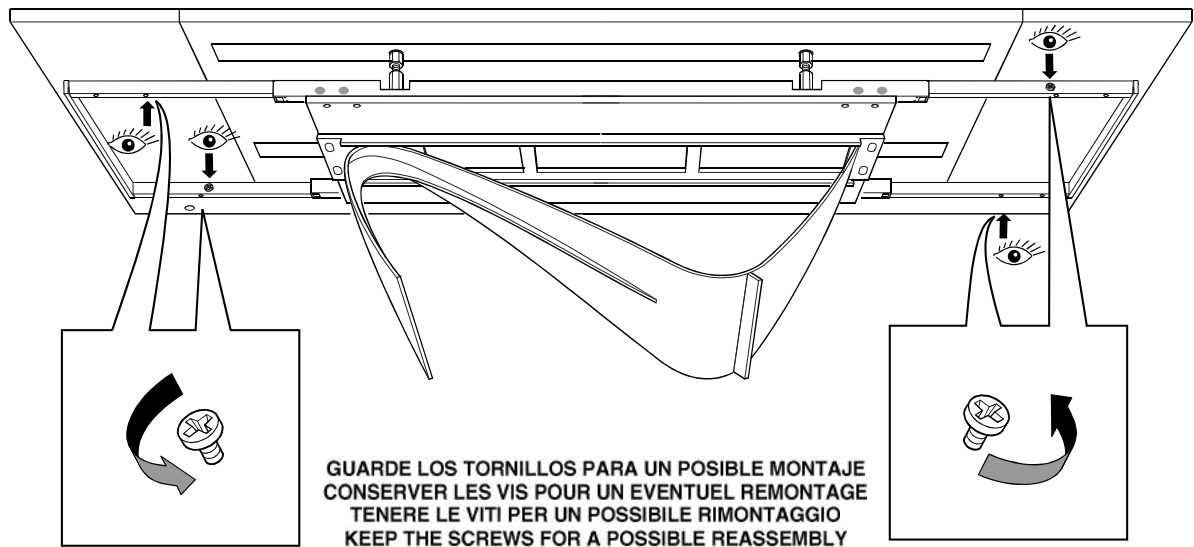

3. Instrucciones para ajustes Instructions pour le réglage Istruzioni per le regolazioni Instructions for adjustments

17

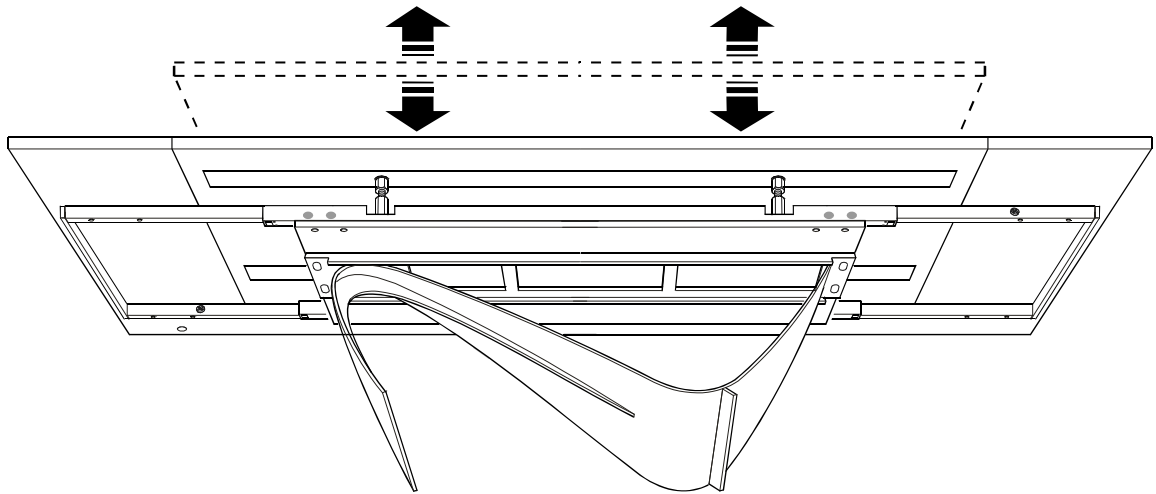

18

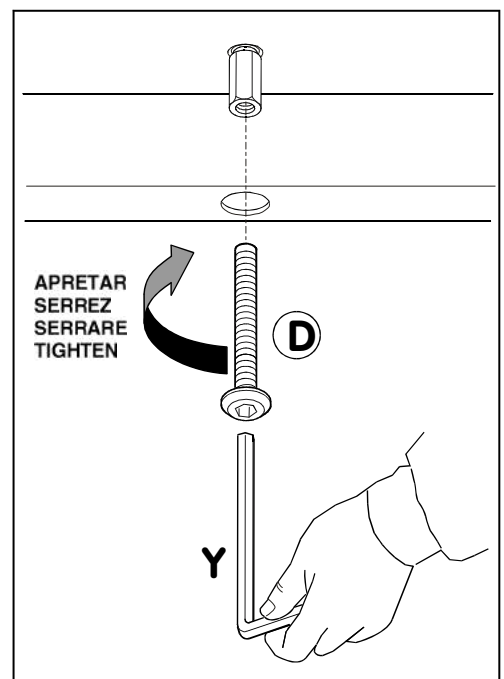
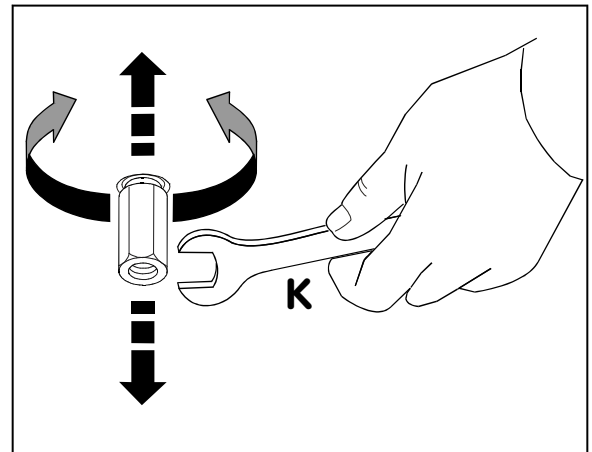
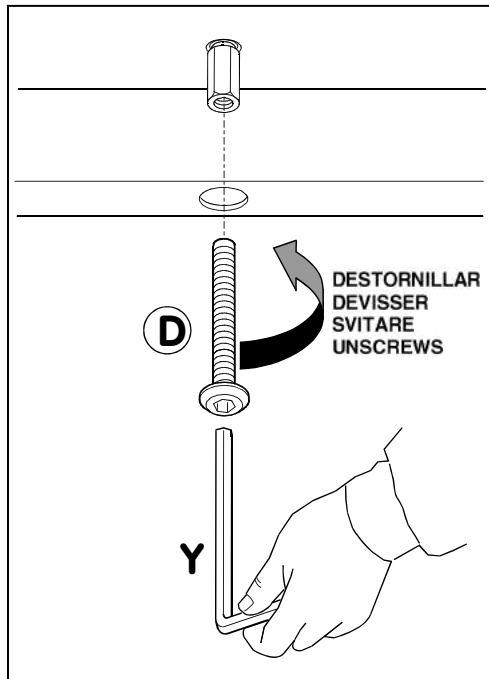

3.

Instrucciones
para ajustes

Instructions
pour le réglage

Istruzioni per
le regolazioni

Instructions for
adjustments

19

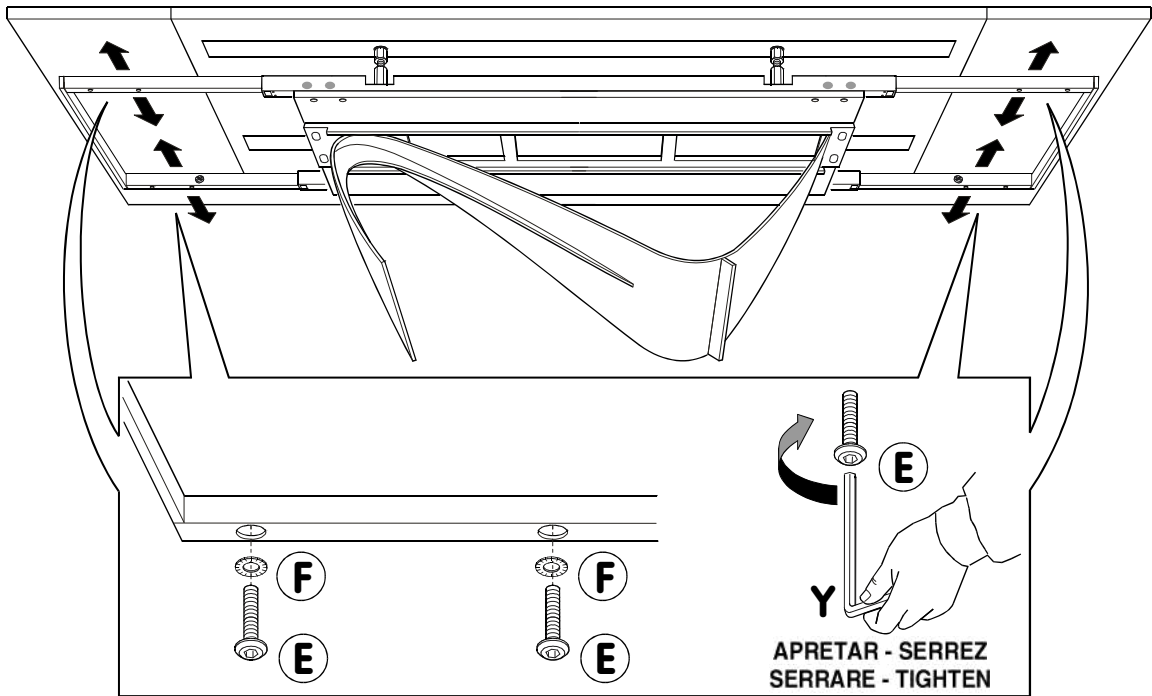

**Limpieza general:**

Siempre elimine las manchas de inmediato. Utilice un paño blanco y limpio.



Usa agua limpia. Si la mancha no se quita, use agua jabonosa. Si usa productos de limpieza, siempre pruébelos primero en un lugar discreto.



PRECAUCIÓN No utilice limpiadores químicos ni productos/materiales abrasivos.

Nettoyage en général:

Toujours éliminer immédiatement les taches. Utiliser un chiffon blanc, propre.

Utiliser une eau propre. Si la tache ne s'enlève pas, utiliser une eau savonneuse. Si un produit de nettoyage est utilisé, toujours l'essayer préalablement dans un endroit invisible.

ATTENTION Ne pas utiliser de produits ou moyens chimiques, agressifs ou abrasifs.

Pulizia generale:

rimuovere sempre subito le macchie. Utilizzare un panno bianco, pulito.

Utilizzare acqua pulita. Se la macchia non viene via, utilizzare dell'acqua con sapone. Se si utilizzano dei detergenti, provarli sempre prima in un punto non visibile.

ATTENZIONE Non utilizzare detergenti chimici o prodotti/materiali abrasivi.

General cleaning instructions:

Always remove stains immediately. Use a clean, white cloth.

Use clean water. If the stain does not come out, use soapy water. If you use cleaning detergents, always test them first in a concealed spot.

CAUTION Do not use any chemical or abrasive cleaning detergents or cloths/tools.

**Cuidado de los muebles:**

limpie la madera lacada utilizando únicamente un paño ligeramente húmedo.

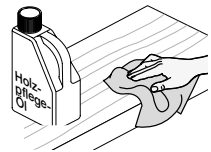

Para mantener su brillo y dependiendo de su uso (por ejemplo, cada 3 meses), las superficies de madera deben pulirse ocasionalmente con una cera natural para muebles de buena calidad usando un paño suave y seco.

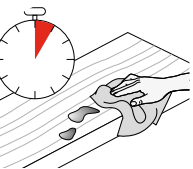

Es necesario eliminar inmediatamente la humedad residual de las superficies, de lo contrario existe el riesgo de que se formen manchas.



PRECAUCIÓN No utilice limpiadores químicos ni productos/materiales abrasivos.

Entretien des meubles:

Essuyer le bois vernis uniquement avec un chiffon légèrement humide.

Pour maintenir toute la brillance de la surface, nous recommandons de la cirer de temps en temps (tous les 3 mois environ) avec une cire naturelle pour meubles de bonne qualité, en utilisant un chiffon doux et sec.

Les restes d'humidité sur les surfaces doivent être immédiatement enlevés. Risque de formation de taches.

ATTENTION Ne pas utiliser de produits ou moyens chimiques, agressifs ou abrasifs.

Cura dei mobili:

pulire il legno laccato utilizzando soltanto un panno leggermente umido.

Affinché mantengano la loro lucentezza e a seconda del loro utilizzo (ad es. ogni 3 mesi), le superfici di legno vanno lucidate occasionalmente con una cera naturale di buona qualità per mobili utilizzando un panno morbido e asciutto.

È necessario eliminare subito i residui di umidità dalle superfici, altrimenti c'è il rischio che si formino delle macchie.

ATTENZIONE Non utilizzare detergenti chimici o prodotti/materiali abrasivi.

Furniture care:

Only wipe varnished wood with a slightly damp cloth.

In order to maintain their shine and based on their use (for example every 3 months) wood surfaces have to be polished occasionally with a good quality natural wax for furniture, using a soft dry cloth.

To prevent stains, immediately wipe off any wet spots on surfaces.

CAUTION Do not use any chemical or abrasive cleaning detergents or cloths/tools.

Bellini

MODERN LIVING